

# € Surface thermometer and thermostat

Devices designed to display, control and regulate cooling generators (manual or automatic programmable defrosting by stopping the compressor) or heating generators.

## 1- Versions and References

MODEL	FUNCTION	RELAY	POWER SUPPLY, 50/60 Hz
AKO-14602	Thermometer	-	230 V ~ ±10%
AKO-14610	Thermostat	16 (4) A, 250 V, cos φ=1, SPST	230 V ~ ±10%

## 2- Technical data

Temperature range according to type of sensor configured:

- NTC ..... -50.0 °C to 99.9 °C (-58.0 °F to 211 °F)
- PTC ..... -50.0 °C to 150 °C (-58.0 °F to 302 °F)

Resolution, Set Point and differential: . . . 0,1 or 1 °C/°F configurable by parameter P7  
Input for probe:

- NTC ..... **AKO-149XX**
- PTC ..... **AKO-1558XX**

Thermometric accuracy: . . . . . ± 1 °C  
Probe tolerance at 25 °C:

- NTC ..... ± 0,4 °C
- PTC ..... ± 1.25 °C

Maximum input power: . . . . . 3 VA

Working ambient temperature: . . . . . 5 °C to 50 °C

Storage ambient temperature: . . . . . -30 °C to 70 °C

Control device classification:

Independent mounting, with characteristic of automatic operation Type 1.B action, to be used in a clean situation, logical medium (software) class A and continuous operation. Degree of contamination 2 on UNE-EN 60730-1

Double insulation between the power supply, the secondary circuit and the relay output. Allocated pulse temperature: . . . . . 2500 V

Pressure ball test temperature:

- Accessible parts . . . . . 75 °C
- Parts that position active elements: . . . . . 125 °C

Voltage and current declared by the EMC tests: . . . . . **AKO-14602:** 207 V, 15 mA

. . . . . **AKO-14610:** 207 V, 17 mA

Current of radio jamming suppression test: . . . . . 270 mA

## 3- Installation

The controller should be installed in a place protected from vibrations, water and corrosive gases, and where ambient temperature does not surpass the value specified in the technical data.

In order to give a correct reading, the probe should be installed in a place without heat influences other than the temperature that is to be measured or controlled.

### 3.1 Fastening:

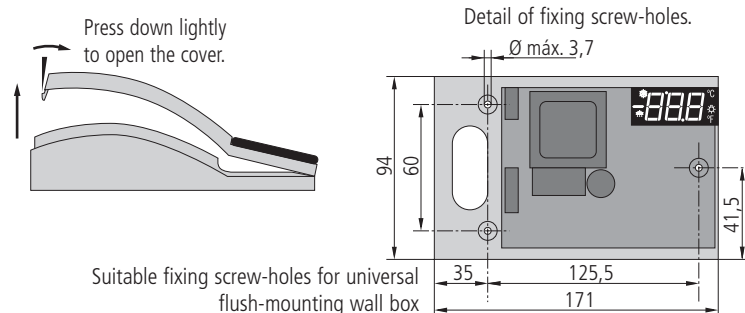

### 3.2 Connection:

The probe and its lead should **NEVER** be installed in ducting along with power, control or power supply wiring.

The power supply circuit should be connected with a minimum 2 A, 230 V, switch located close to the unit. Power supply cables should be H05VV-F 2x0,5 mm<sup>2</sup> or H05V-K 2x0,5 mm<sup>2</sup>

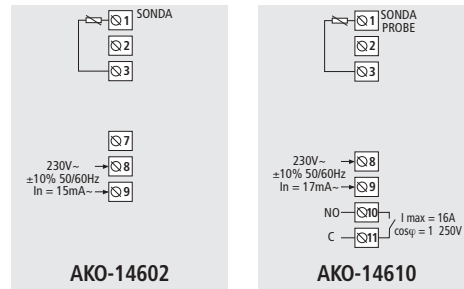

Section of connecting wires for relays contacts should be 2,5 mm<sup>2</sup>.

## 4- Front panel functions

### LED Compressor ❄️

**Permanent:** Relay (compressor) energised if control operates in cold.

**Flashing:** Because of the temperature detected by Sensor, the COOL relay should be energised, but is no due to a programmed parameter.

### LED Heat 🔥

**Permanent:** Relay energised if control operates in heat.

**Flashing:** Because of the temperature detected by Sensor, the relay should be energised, but is no due to a programmed parameter.

### LED Defrost ❄️ (Def)

**Permanent:** Indicates defrost in operation

### LED °C

**Permanent :** Degrees °C indicator.

**Flashing :** Programming phase.

### LED °F

**Permanent :** Degrees °F indicator.

**Flashing :** Programming phase.

### UP key ⬆️

- In programming, it makes the displayed value increase.

- When pressed for at least 5 seconds,

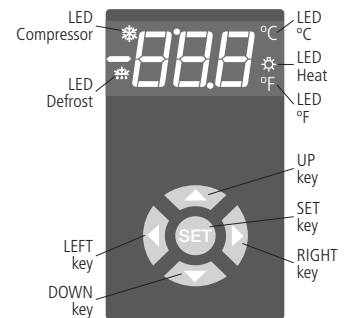

a manual defrost is started with programmed duration.

### DOWN key ⬇️

- In programming, it makes the displayed value reduce

### RIGHT key ➡️

- In programming, it makes the level value increase.

### LEFT key ⬅️

- Exit programming level.

### SET key

- In programming, accept the programmed new value.

- When pressed for at least 5 seconds, the SP Set Point temperature is displayed.

## 5- Adjustment and configuration

It should only be programmed or modified by personnel who are fully conversant with the equipment operation and possibilities..

### 5.1 Set Point temperature

The factory SET POINT default value is 0.0 °C.

- Press key for at least 5 seconds to DISPLAY SET POINT. It displays the CURRENT SET POINT value and LED °C or °F starts flashing.

- Press or keys to CHANGE SET POINT into the required value.

- Press key to ACCEPT THE NEW SET POINT. The display returns to the CURRENT TEMPERATURE display status and LED °C or °F stops flashing.

- Press the key to exit the temperature set point without modifying the value.

When **PA** is displayed, PASSWORD programmed in **L5** parameter of **tid** menu should be entered to access the CURRENT SET POINT.

- Press key. 0 will be displayed to ENTER PASSWORD.

- Press or keys to CHANGE NUMBER and DISPLAY PASSWORD programmed.

- Press key to ACCEPT PASSWORD. The CURRENT SET POINT value will be displayed and it can be already modified.

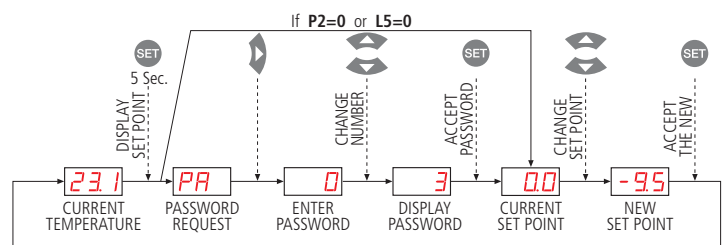

## 5.2 Parameters configuration

### Level 1 Menus

Press simultaneously + keys for at least 10 seconds. LED °C or °F will be flashing, we are in the programming LEVEL 1 MENUS and the first menu "rE" is displayed.

- Press key to access the next menu and key to return to previous one.
- Pressing key, the controller returns to the CURRENT TEMPERATURE display status and LED °C or °F will stop flashing.

When PA, is displayed, PASSWORD programmed in L5 of "tid" menu should be entered to access programming LEVEL 1 MENUS.

- Press key. 0 will be displayed to ENTER PASSWORD.
- Press or keys to CHANGE NUMBER and DISPLAY PASSWORD programmed.
- Press key to ACCEPT PASSWORD. The first menu "rE" will be displayed.

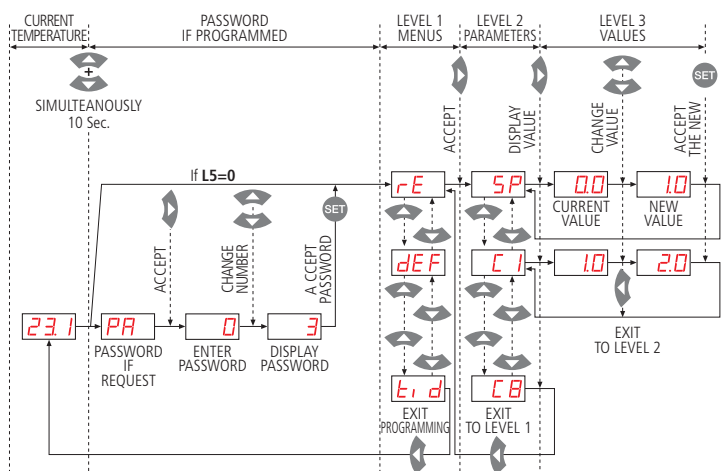

### Level 2 Parameters

- In the desired menu of LEVEL 1 MENUS, press key. LEVEL 2 PARAMETERS programming is accessed. The first parameter of the selected menu is displayed on the screen.
- Press key to access the next parameter and key to return to the previous one.
- Pressing key, the controller returns to the LEVEL 1 MENUS.

### Level 3 Values

- To DISPLAY the CURRENT VALUE of any parameter, select the required one and press key. Once it is displayed, you can CHANGE VALUE, pressing or key.
- Press key to ACCEPT THE NEW. The programming returns to LEVEL 2 PARAMETERS.
- Pressing key, the controller returns to the LEVEL 2 PARAMETERS

**REMARK:** If no key is pressed for 25 seconds in either of the previous steps, the controller will automatically return to the CURRENT TEMPERATURE display status without modifying any of the parameters values.

## 6- Description of parameters and messages

Values in the Def. column are factory-set

AKO-14602						
AKO-14610						
Level 1 Menus and Description						
rE	Level 2	Level 3	Description	Values	Min.	Def. Max.
	SP		Set Point temperature	(°C/°F)	-58.0	0.0 350
	C0		Sensor calibration (Offset)	(°C/°F)	-20.0	0.0 20.0
	C1		Sensor differential (Hysteresis)	(°C/°F)	0.1	2.0 20.0
	C2		Set Point upper limit (It cannot be set above this value)	(°C/°F)	C3	99.9 350
	C3		Set Point lower limit (It cannot be set below this value)	(°C/°F)	-58.0	-50.0 C2
	C4		Relay protection delay type: 0=OFF/ON (From the last switch-off) 1=ON (At switch-on)		0	0 1
	C5		Protection delay time (Value for the option selected in parameter C4)	(min.)	0	0 255
	C7		Relay time in ON in case of faulty sensor (if C7=0 and C8≠0, the relay will always be OFF disconnected)	(min.)	0	10 255
	C8		Relay time in OFF in case of faulty sensor (if C8=0 and C7≠0, the relay will always be ON connected)	(min.)	0	5 255

AKO-14602						
AKO-14610						
Level 1 Menus and Description						
dEF	Level 2	Level 3	Description	Values	Min.	Def. Max.
	dEF		DEFROST control (if P0=0 Direct, Cold)			
		d0	Defrost frequency (Elapsed time between 2 starts)	(h.)	0	6 120
		d1	Defrost maximum duration	(min.)	0	30 255
		d2	Type of message during defrost: (0=Current temperature display) (1=Defrost start temperature display) (2=Display dEF message)		0	2 2
		d3	Message maximum duration (Time added at the end of defrost)	(min.)	0	5 255
CnF Level 2 GENERAL STATUS						
	Level 3		Description	Values	Min.	Def. Max.
	P0		Type of operation (0 = Direct, Cold) (1 = Reverse, Heat)		0	0 1
	P1		Delay of all functions on power supply switch on	(min.)	0	0 255
	P2		Allocation of password to Set Point: (0=Without allocation) (1=With allocation of L5 password)		0	0 1
	P3		Initial parameters: (1=YES, configure to "Def" and exit programming)		0	0 1
	P5		Address for units with communication		0	0 255
	P7		Temperature display mode: (0=Integers in °C) (1=One decimal in °C) (2=Integers in °F) (3=One decimal in °F)		0	1 3
	P9		Sensor type selection: (0=NTC) (1=PTC)		0	0 1
tid Level 2 ACCESS AND INFORMATION control						
	Level 3		Description	Values	Min.	Def. Max.
	L5		Access password to parameters and information		0	0 255
	L6		Parameters transfer: (0=Disabled) (1=Send) (2=Receive)		0	0 2
	PU		Program version (Information)			

**REMARK:** When time parameters are modified, the new values are applied when the current cycle is completed. In order for it to have an immediate effect, switch the controller off and then on again.

### MESSAGES

PA	Password request to enter programming parameters or SET POINT
dEF	It indicates defrosting is being carried out. In order to display "dEF" during defrosting, it is essential that parameter d2 is set to option 2.
E1	Sensor failure (Open circuit, crossed, NTC: temp.> 110°C or temp.<-55°C PTC: temp.> 150°C ó temp.<-58°C)
EEE	Memory failure

## 7- Parameters transfer

### Portable server

AKO-14918, portable server, with no power supply, in which parameters programmed in a powered controller can be copied by transfer. Parameters can be transferred again from the server to other identical powered controllers.

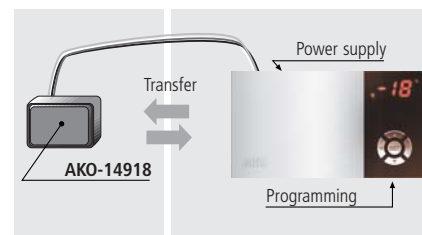

## 8- Maintenance

Clean the controller surface with a soft cloth, soap and water. Do not use abrasive detergents, petrol, alcohol or solvents.

## 9- Warnings

The use of the unit without observing the manufacturer's instructions may alter its safety qualification.

To ensure correct operation of the apparatus, only NTC or PTC type probes supplied by AKO should be used.

Between -40 °C and +20 °C, when the NTC probe is extended up to 1.000 m with minimum 0,5 mm<sup>2</sup> cable, deviation will be less than 0.25 °C (Probe extension cable ref. AKO-15586)